

# QWX27120 Product Brief

## 5-7 GHz Wi-Fi 7 CMOS Front-End IC

### Applications

- Wi-Fi 7 and Wi-Fi 8 systems
- Smartphones and other portable, rechargeable battery-operated devices
- Smart TV, set-top boxes, AR/VR headsets

### Features

- PA with superior linear output power and best-in-class power efficiency for Wi-Fi 7 and Wi-Fi 8 high data rate applications
- Monolithic die implementation in CMOS SOI ensures smallest form factor
- LNA with bypass mode and industry leading current consumption
- High gain and low gain transmit modes
- Power detector output

### Key Specifications

- 5150 – 7125 MHz
- Single 3.80V supply voltage
- Transmit output power:
  - 21.5 dBm, 20 MHz, 3 dB SEM margin
  - 18.5 dBm, EHT160 -35 dB DEVM
  - 16.5 dBm, EHT160 -42 dB DEVM
  - 11 dBm, EHT320 -45 dB DEVM
- Transmit gain: 28.5 dB (high gain mode)
- Current consumption:
  - 305 mA at 21 dBm output power
- Noise figure: 2.1 dB
- Receive gain: 16 dB

### Functional Block Diagram

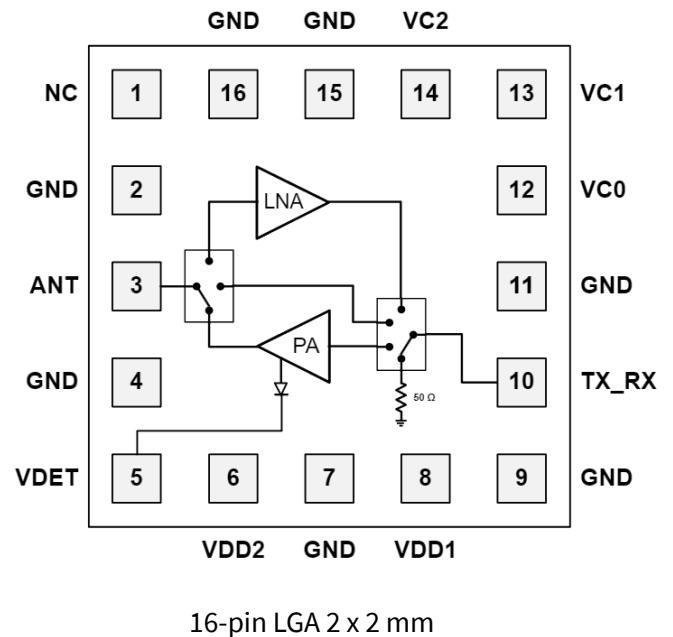

### Description

The QuantalRF QWX27120 is a highly integrated monolithic front-end IC designed for high performance Wireless Local Area Network (WLAN) applications supporting all standards up to Wi-Fi 8. It features a patent pending PA architecture providing superior power efficiency, a low loss single-pole, triple-throw (SP3T) switch and an LNA.

Support for Digital Pre-Distortion (DPD) is implemented in both transmit modes for further improved EVM performance.

All RF ports are matched on-chip to 50 ohms to minimize the external components and application layout area.

The QWX27120 is fabricated as a monolithic die in CMOS SOI technology.

## Pin Configuration and Description

Pin No.	Label	Description
1	NC	No connect
2, 4, 7, 9, 11, 15, 16	GND	Ground
3	ANT	Bidirectional antenna port, matched to 50Ω
5	VDET	Power detector output
6	VDD2	3.80V supply
8	VDD1	3.80V supply
10	TX_RX	Bidirectional TX/RX input/output port
12, 13, 14	VC0, VC1, VC2	Control signals

## RoHS Compliance

The part is compliant with the 2011/65/EU RoHS directive, as amended by Directive 2015/863/EU.

## Contact Information

For the latest specifications, additional product information and support:

[sales@quantalrf.com](mailto:sales@quantalrf.com)

Learn more at [quantalrf.com](http://quantalrf.com)

## Disclaimer

**Limited warranty and liability** - Information in this document is believed to be accurate and reliable. However, QuantalRF does not give any representations or warranties, expressed or implied, as to the accuracy or completeness of such information and shall have no liability for the consequences of the use of such information.

**Right to make changes** - QuantalRF reserves the right to make changes to information published in this document, including without limitation specifications and product descriptions, at any time and without notice. This document supersedes and replaces all information supplied prior to the publication hereof.